

1.0 GENERAL DESCRIPTION

This series of graphical 140 x 32 dot matrix Vacuum Fluorescent Display (VFD) modules is capable of displaying both graphics and text using built-in font tables. The modules contain VFD driver circuitry, one microcontroller, one DC-DC/AC converter and various host interfaces.

A six-pin connector supports the serial interface connections and a fourteen-pin connector supports the parallel interface. The NAGP1250AA module uses a fourteen position in-line connector and the NAGP1250BA uses a two rows by seven pins connector. Both connections also require a 5VDC power supply to operate the module. See sections *System Block Diagram* and *Parallel Interface Connector* and *Serial Interface Connector* for more detail.

1.1 FEATURES

- 5VDC operation
- -40°C to +85°C operation
- displays both graphics and text simultaneously
- 140 x 32 dot matrix with fixed and proportional fonts for smoother character spacing
- 14 international font sets with up to 16 user defined characters
- font magnification up to 4X horizontally and 2X vertically
- 1000 cd/m² maximum luminance and wide viewing angles
- 8 levels of brightness control from 12.5% to 100%
- screen saver modes to reduce power consumption and to reduce image burn-in
- up to 4 screen windows with independent control
- variable speed scrolling
- legendary Futaba quality and reliability
- choice of serial and parallel interfaces

NAGP1250AA/BA-0: parallel and RS-232 asynchronous serial communication (9.6K – 115.2K baud)

NAGP1250AA/BA-2: parallel, synchronous and asynchronous serial communication (9.6K – 115.2K baud)

NAGP1250AA/BA-3: synchronous and asynchronous serial communication (9.6K – 115.2K baud)

2.0 APPLICABLE DOCUMENTS

- Futaba Vacuum Fluorescent Display Specification GP1250AI
- Futaba America Engineering Standard FAES 801, Printed Circuit Board Markings

Futaba®

Futaba Corporation of America Schaumburg, IL

PART NUMBER:

NAGP1250AA4/BA5-0, -2, -3

DATE PRINTED:

04Feb10

REVISION:

A4/A5

SHEET:

2 OF 42

3.0 GENERAL SPECIFICATIONS

Item		Value
number of dots		140 columns X 32 rows
dot height (mm)		0.57
dot width (mm)		0.4
dot pitch vertical (mm)		0.67
dot pitch horizontal (mm)		0.5
pattern width (mm)		69.9
pattern height (mm)		21.34
peak wavelength of illumination		green x = 0.24, y = 0.41
Luminance (cd/m ²)	min.	500 @ 100% luminance
	typ.	1000 @ 100% luminance

Futaba[®]

Futaba Corporation of America Schaumburg, IL

PART NUMBER:

NAGP1250AA4/BA5-0, -2, -3

REVISION:

A4/A5

DATE PRINTED:

04Feb10

SHEET:

3 OF 42

3.1 MECHANICAL DRAWINGS

3.1.1 NAGP1250AA

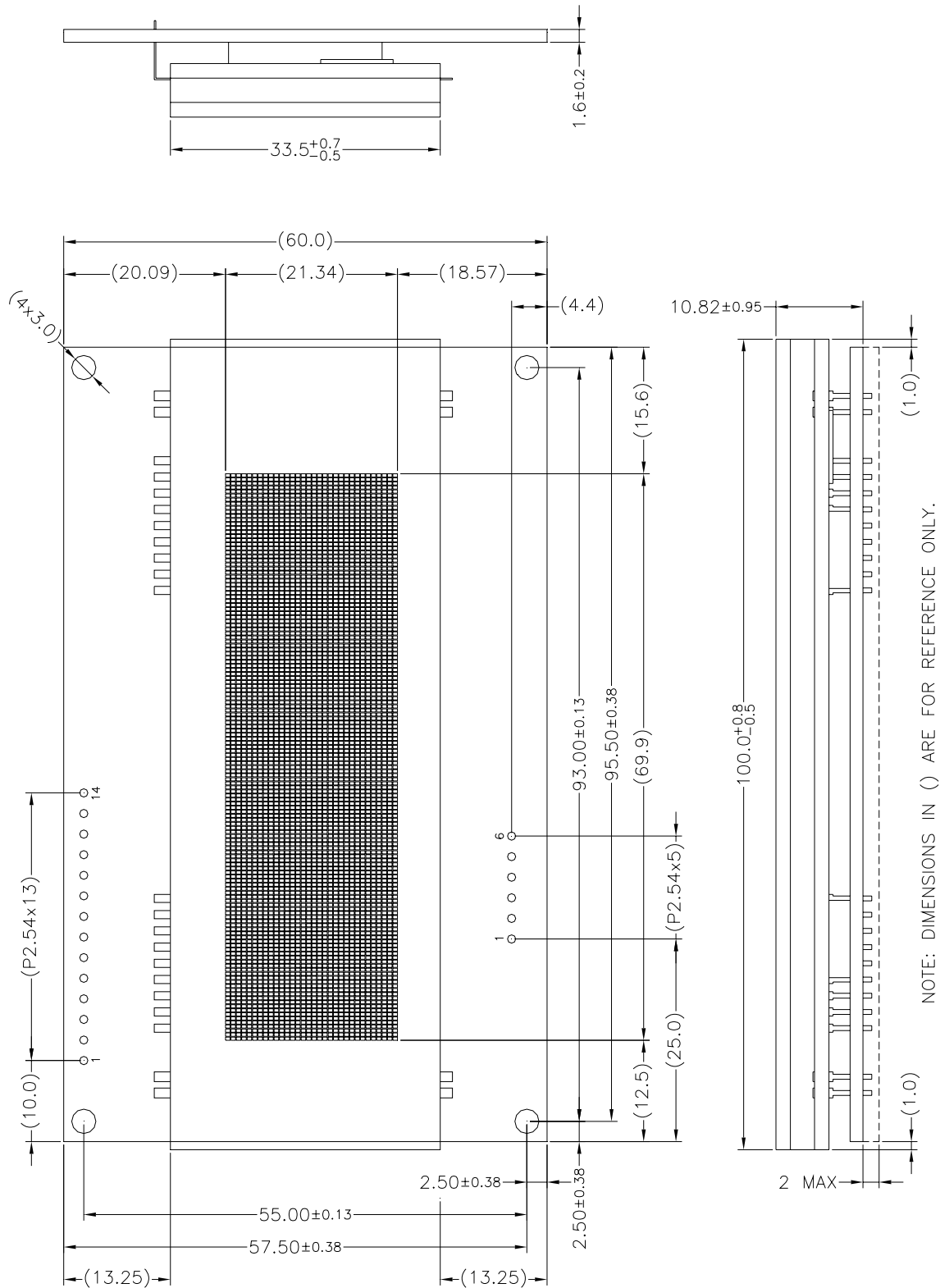

Futaba®

Futaba Corporation of America Schaumburg, IL

PART NUMBER:

NAGP1250AA4/BA5-0, -2, -3

DATE PRINTED:

04Feb10

REVISION:

A4/A5

SHEET:

4 OF 42

3.2 SYSTEM BLOCK DIAGRAM

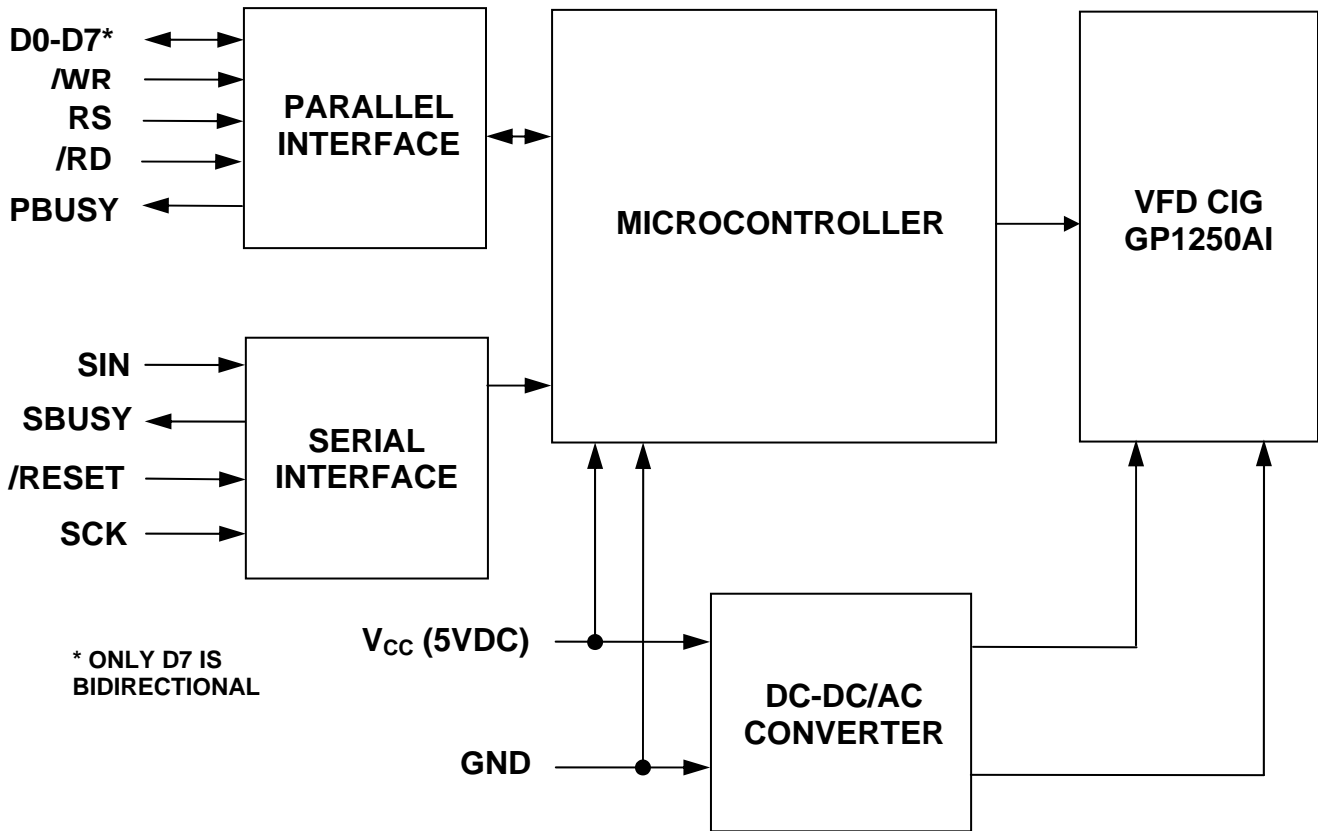

3.3 ENVIRONMENTAL SPECIFICATIONS

Item	Symbol	Min.	Max.	Unit	Comment
operating temperature	Topr	-40	+85	°C	
storage temperature	Tstg	-40	+85	°C	
operating humidity	Hopr	-	85	%RH	without condensation
storage humidity	Hstg	-	90	%RH	without condensation
Vibration	-	-	4	G	total amplitude: 1.5mm freq: 10 ~ 55 Hz sine wave sweep time: 1 min / cycle duration: 2 hrs / axis (X, Y, Z)
Shock	-	-	40	G	duration: 11ms waveform: half sine wave 3 times / axis (X, Y, Z, -X, -Y, -Z)

Futaba®

Futaba Corporation of America Schaumburg, IL

PART NUMBER:

NAGP1250AA4/BA5-0, -2, -3

DATE PRINTED:

04Feb10

REVISION:

A4/A5

SHEET:

6 OF 42

3.4 ABSOLUTE MAXIMUM SPECIFICATIONS

Item	Symbol	Min.	Max.	Unit
supply voltage	V_{CC}	-0.3	6.0	V
input signal voltage D0-D7, /WR,/RD/ RESET, SIN	V_{IS}	-0.3	$V_{CC}+0.3$	V
input signal voltage SIN RS-232 only	V_{IRS232}	-20.0	20.0	V

3.5 DC ELECTRICAL SPECIFICATIONS

Item	Symbol	Min.	Typ.	Max.	Unit
supply voltage	V_{CC}	4.75	5.0	5.25	V
supply current	I_{CC}	-	400	500	mA
high-level input signal voltage (except RS-232 SIN)	V_{IH}	$0.8 * V_{CC}$	-	V_{CC}	V
low-level input signal voltage (except RS-232 SIN)	V_{IL}	0.0	-	$0.2 * V_{CC}$	V
high-level input signal voltage (RS-232 SIN only)	$V_{IHRS232}$	3.0	-	15.0	V
low-level input signal voltage (RS-232 SIN only)	$V_{ILRS232}$	-15.0	-	0.5	V
high-level output signal voltage (see Notes 1 & 2)	V_{OH}	4.0	-	V_{CC}	V
low-level output signal voltage (see Note 1)	V_{OL}	0	-	0.5	V

Notes:

- $V_{CC} = 5.0V$, $R_L = 3K\Omega$ to GND
- SBUSY is an open collector output.

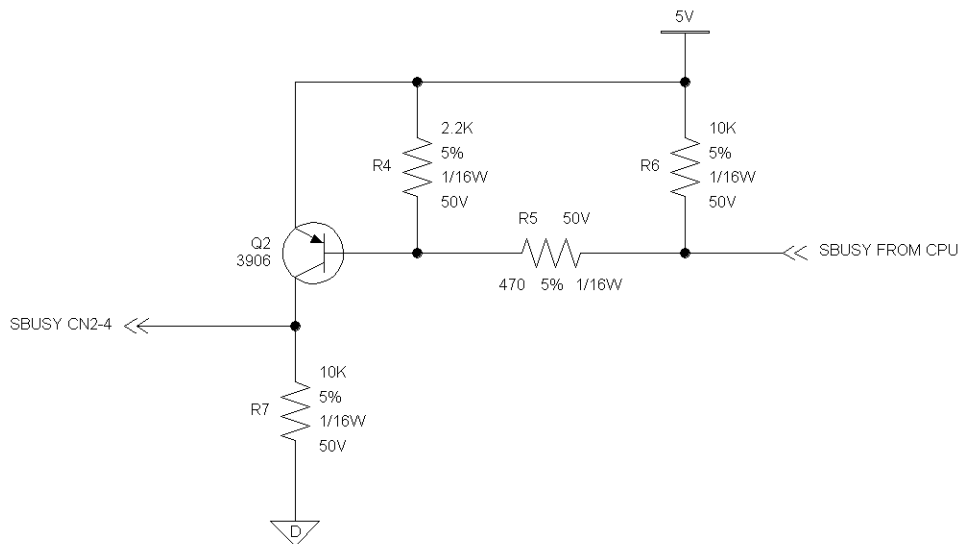

Futaba®

Futaba Corporation of America Schaumburg, IL

PART NUMBER:

NAGP1250AA4/BA5-0, -2, -3

DATE PRINTED:

04Feb10

REVISION:

A4/A5

SHEET:

7 OF 42