

APPLICATION NOTE

VACUUM FLUORESCENT DISPLAY MODULE

AN-E-3153B



GRAPHIC DISPLAY MODULE

GP1041A01A INSTRUCTION MANUAL

GENERAL DESCRIPTION

FUTABA GP1041A01A is a graphic display module using a FUTABA 256×16 VFD.

It consists of a driver, a control circuit and power source.

The module can be connected directly to the bus line of the host system CPU.

Important Safety Notice

Please read this note carefully before using the product.

Warning

- The module should be disconnected from the power supply before handling.
- The power supply should be switched off before connecting or disconnecting the power or interface cables.
- The module contains electronic components that generate high voltages which may cause an electrical shock when touched.
- Do not touch the electronic components of the module with any metal objects.
- The VFD used on the module is made of glass and should be handled with care. When handling the VFD, it is recommended that cotton gloves be used.
- The module is equipped with a circuit protection fuse.
- Under no circumstances should the module be modified or repaired. Any unauthorized modifications or repairs will invalidate the product warranty.

1. FEATURES

- 1-1. High quality and long life can be achieved with FUTABA VFD.
- 1-2. Compact and light-weight unit by using packed display drivers and one-chip VFD control.
- 1-3. Driven through a simple interface.
- 1-4. High speed 8bits data write-in capability.

2. GENERAL SPECIFICATIONS

2-1. DIMENSIONS, WEIGHT (Refer to APPENDIX-1)

Table-1

Item	Specification	Unit
Outer Dimensions	(L) 385±0.5	mm
	(W) 59.5±0.4	
	(T) 32 Max.	
Weight	560 Max.	g

2-2. SPECIFICATIONS OF THE DISPLAY PANEL

Table-2

Item	Specification	Unit
Display Area	309.46×26.1	mm
Number of Dots	256×16	Dot
Dot Pitch	1.21×1.65	mm
Dot Size	0.91×1.35	mm
Color Illumination	Green ($\lambda_p=505\text{nm}$)	—
Luminance	620(180fL)Typ.	cd/m ²

(Note)

By using a filter, uniform color ranging from blue to orange (including white) can be obtained.

2-3. ENVIRONMENT CONDITIONS

Table-3

Item	Symbol	Min.	Max.	Unit
Operating Temperature	T_{opr}	0	60	°C
Storage Temperature	T_{stg}	-20	+70	°C
Operating Humidity	H_{opr}	20	80	%
Storage Humidity	H_{stg}	20	90	%
Vibration (10~55Hz)	—	—	4	G
Shock	—	—	40	G

(Note) Avoid operations and or storage in moist environmental conditions.

2-4. ABSOLUTE MAXIMUM RATINGS

Table-4

Item	Symbol	Min.	Max.	Unit
Supply Voltage	V_{cc}	-0.5	7.0	Vdc
Input Signal Voltage	V_{IS}	0.5	$V_{cc}+0.5$	V

2-5. RECOMMENDED OPERATING CONDITIONS

Table-5

Item	Symbol	Min.	Typ.	Max.	Unit
Supply Voltage	V_{cc}	4.5	5.0	5.5	Vdc
H-Level Input Voltage	V_{IH}	2.2	—	—	V
L-Level Input Voltage	V_{IL}	—	—	0.8	V

2-6. ELECTRICAL CHARACTERISTICS

Table-6

Item	Symbol	Condition	Min.	Typ.	Max.	Unit
Supply Current *1	I_{cc}	$V_{cc}=5.0V$	—	2.0	2.5	A
Power Consumption	—		—	10	12.5	W
Luminance	L	All on	150	620	—	cd/m ²
H-Level output Voltage	V_{OH}	$V_{cc}=4.5V$ $I_{OH}=-2mA$	3.8	—	—	V
L-Level output Voltage	V_{OL}	$V_{cc}=4.5V$ $I_{OL}=3.2mA$	—	—	0.4	V

Note *1)

The surge current can be approx. 5 times the specified supply current at power on.

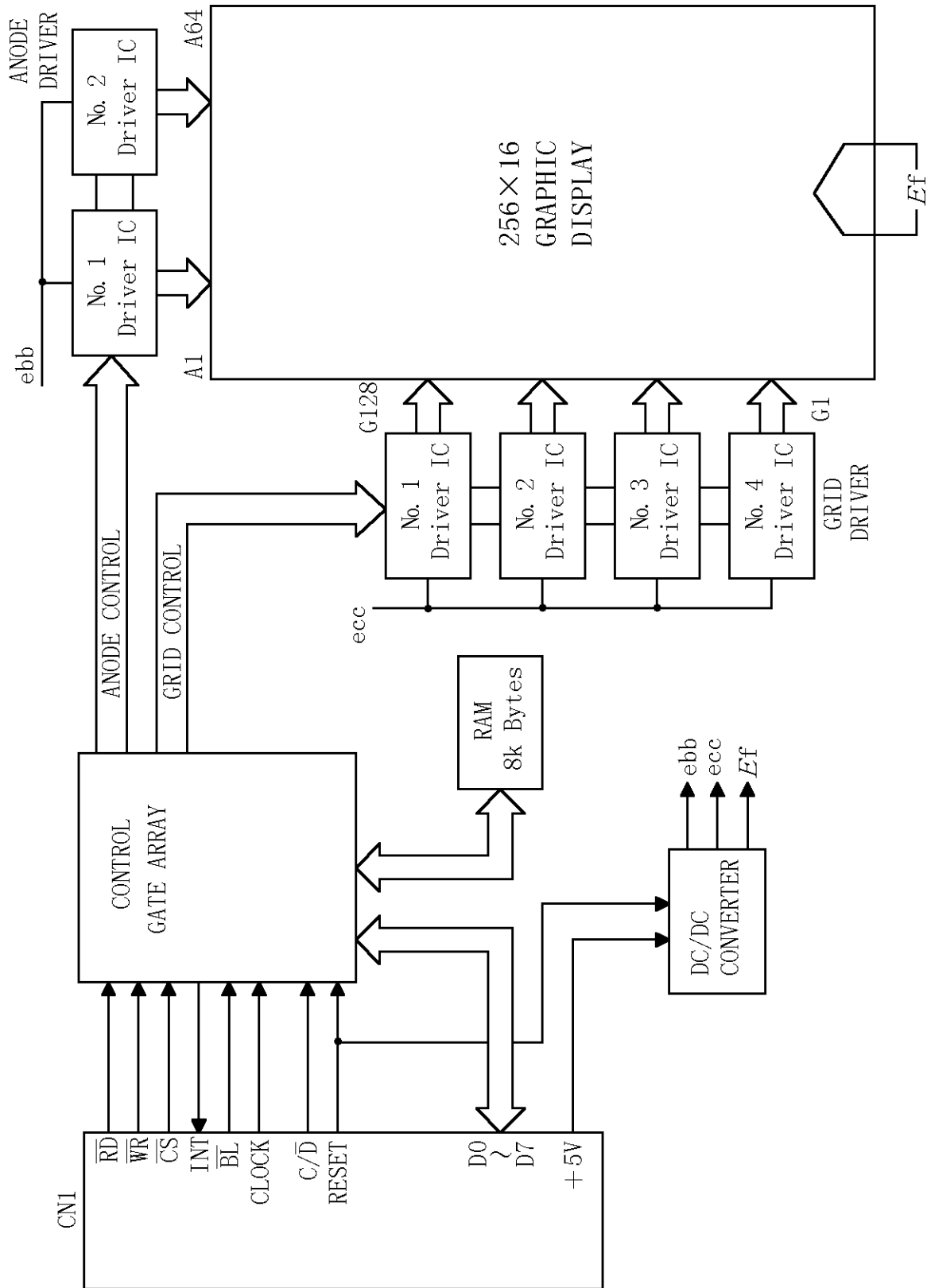

5. WARRANTY

This display module is guaranteed for 1 year after the shipment from FUTABA.

6. CAUTIONS FOR OPERATION

- 6-1. Since VFDs are made of glass material.
Avoid applying excessive shock or vibration beyond the specification for the module.
Careful handling is essential.
- 6-2. Applying lower voltage than the specified may cause non activation for selected pixels.
Conversely, higher voltage may cause non-selected pixel to be activated.
If such a phenomenon is observed, check the voltage level of the power supply.
- 6-3. Avoid plugging or unplugging the interface connection with the power on.
- 6-4. DC/DC converter is equipped on the module, the surge current may be approximately 5 times the specified supply current at the power on.
- 6-5. The DC/DC converter generated approximately 100Vdc, avoid touching it with bare hands, or to other circuits.
- 6-6. Avoid using the module where excessive noise interface is expected.
Noise affects the interface signal and causes improper operation.
Keep the length of the interface cable less than 50cm.
(When the longer cable is required, please confirm there is no noise affection.)
- 6-7. When power is turned off, the capacitor will not discharge immediately.
Avoid touching IC and others.
The shorting of the mounted components within 30 sec., after power off, may cause damage.
- 6-8. The fuse is mounted on the module as circuit protection.
If the fuse blown, the problem shall be solved first and change the fuse.
- 6-9. When fixed pattern is displayed for a long time, you may see uneven luminance.
It is recommended to change the display patterns sometimes in order to keep best display quality.

REMARKS:

The specification is subject to change without prior notice in order to improve the design and quality.
Your consultation with FUTABA sales office is recommended for the use of this module.