

VACUUM FLUORESCENT DISPLAY MODULE

ENGINEERING PROPOSAL

GP1127A01A

EVALUATION

- ACCEPTED WITHOUT ANY CHANGE
 THE FOLLOWING CHANGE IS REQUIRED

30 September 2003

VFD MODULE GROUP

Futaba Corporation

ISSUED BY

Hideki Miyozaki

CHECKED BY

Idiroyuki Takano

CHECKED BY

Katsunori Kase

APPROVED BY

Toshihiro Yamaguchi

Important Safety Notice

Please read this note carefully before using the product.

Warning

- The module should be disconnected from the power supply before handling.
- The power supply should be switched off before connecting or disconnecting the power or interface cables.
- The module contains electronic components that generate high voltages (approx.60V) which may cause an electrical shock when touched.
- Do not touch the electronic components of the module with any metal objects.
- The VFD used on the module is made of glass and should be handled with care. When handling the VFD, it is recommended that cotton gloves be used.
- The module is equipped with a circuit protection fuse.
- Under no circumstances should the module be modified or repaired. Any unauthorized modifications or repairs will invalidate the product warranty.
- The module should be abolished as the factory waste.

1. FEATURES

FUTABA GP1127A01A is a graphic display module using a FUTABA 160×32dots VFD.

It consists of a control ASIC with internal Static-RAM of 2320bytes and power source.

The module can be connected directly to the bus-line of the host system CPU.

2. GENERAL DESCRIPTION

2-1. DIMENSIONS, WEIGHT (Refer to FIGURE-1)

Table-1

Item	Specification	Unit
Outer dimensions	(W) 130.2±1	mm
	(H) 43±1	
	(T) 26.2 MAX.	
Weight	Approx. 100	g

2-2. SPECIFICATIONS OF THE DISPLAY PANEL

Table-2

Item	Specification	Unit
Display Area	71.9(W)×14.3(H)	mm
Number of Dots	160×32	Dot
Dot Size (H×W)	0.35×0.35	mm
Dot Pitch (H×W)	0.45×0.45	mm
Color Illumination	Green (λ p=505nm)	–
Luminance	500 (Typ)	cd/m ²

Note) By using a filter, uniform color range from blue to orange (including white) can be obtained.

2-3. ENVIRONMENT CONDITIONS

Table-3

Item	Symbol	Min.	Max.	Unit
Operation Temperature	<i>Topr</i>	-20	+70	°C
Storage Temperature	<i>Tstg</i>	-30	+80	°C
Operating Humidity	<i>Hopr</i>	20	85	%
Storage Humidity	<i>Hstg</i>	20	90	%
Vibration (10 ~ 55Hz)	–	–	4	G
Shock	–	–	40	G

Note) Avoid operations and or storage in moist environmental conditions.

2-4. ABSOLUTE MAXIMUM RATINGS

Table-4

Item	Symbol	Min.	Max.	Unit
Supply Voltage	V_{CC}	-0.3	6.0	Vdc
Input Signal Voltage	V_{IS}	-0.3	$V_{CC}+0.3$	V

2-5. RECOMMEND OPERATING CONDITIONS

Table-5

Item	Symbol	Min.	Typ.	Max.	Unit
Supply Voltage	V_{CC}	4.5	5.0	5.5	Vdc
H-Level Input Voltage	V_{IH}	2.6	–	–	V
L-Level Input Voltage	V_{IL}	–	–	0.7	V

2-6. ELECTRICAL CHARACTERISTICS

Table-6

Item	Symbol	Condition	Min.	Typ.	Max.	Unit
Supply Current (Note1)	I_{CC}	$V_{CC} = 5.0\text{Vdc}$ All on	–	500	600	mA
Power Consumption	–		–	2.5	3.0	W
Luminance	L		250	500	–	cd/m ²
H-Level Output Voltage	V_{OH}	$V_{CC} = 4.5\text{Vdc}$ $I_{OH} = -2\text{mA}$	3.6	–	–	V
L-Level Output Voltage	V_{OL}	$V_{CC} = 4.5\text{Vdc}$ $I_{OL} = 3.2\text{mA}$	–	–	0.5	V

Note) The surge current can be approx. 5 times the specified supply current at power on.

6. OUTER DIMENSION

FIGURE-4

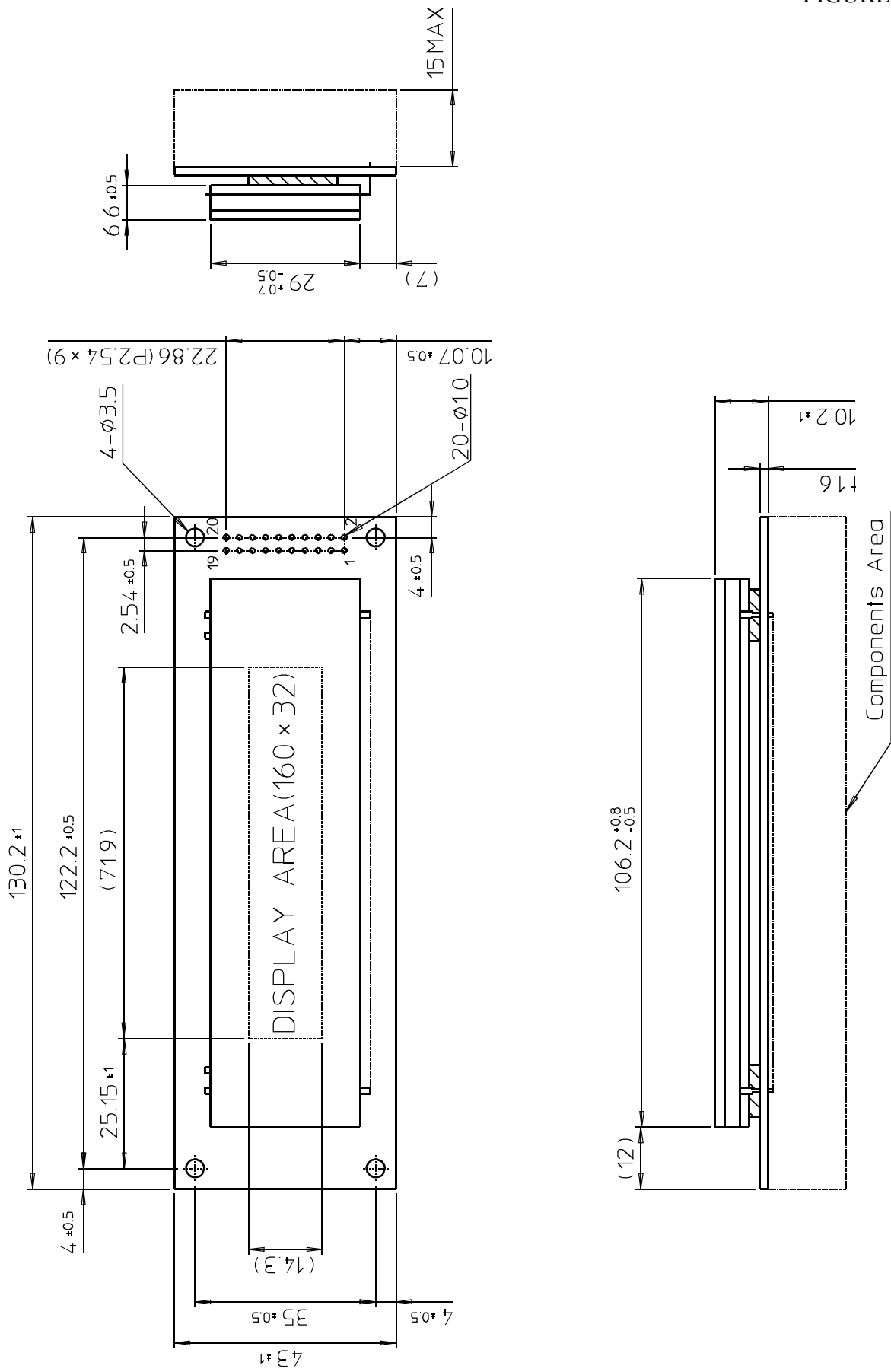

7. CIRCUIT BLOCK DIAGRAM

FIGURE-5

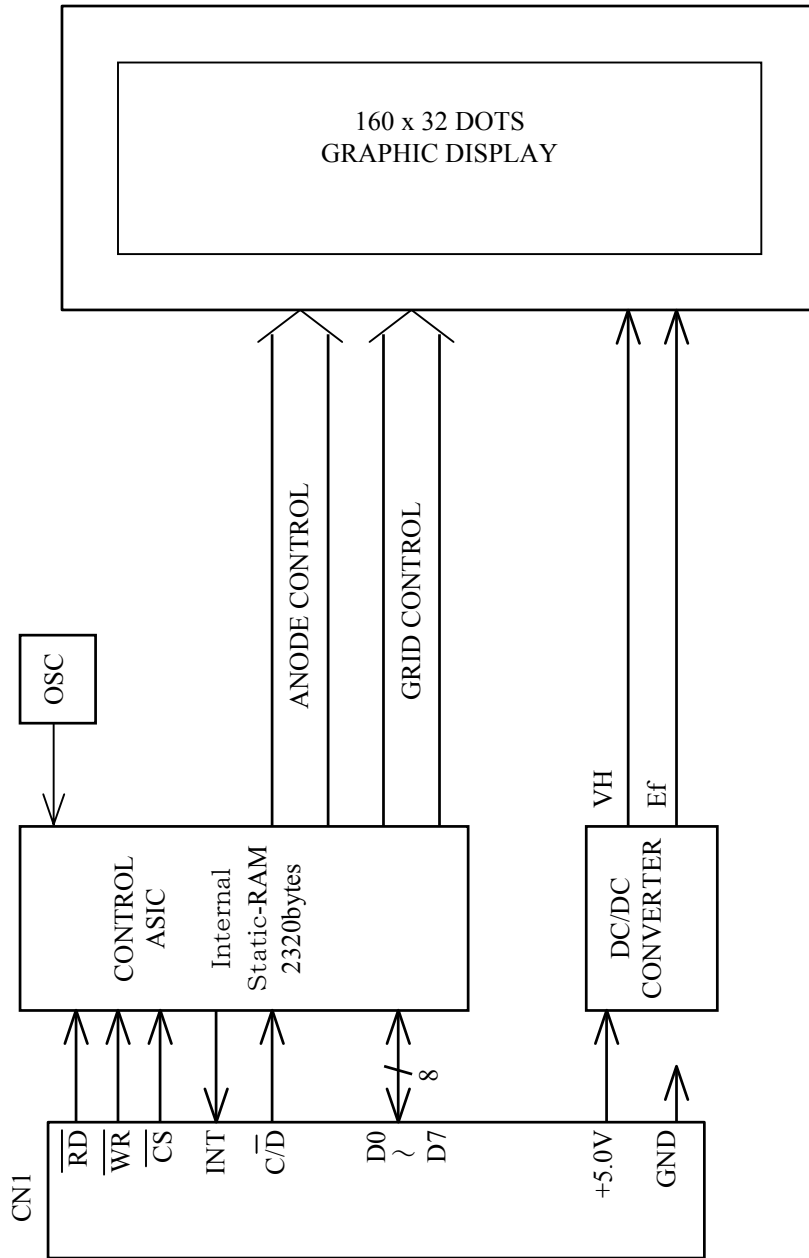

8. CAUTIONS FOR OPERATION

- 8-1. Applying lower voltage than the specified may cause non activation for selected pixels.
Conversely, higher voltage may cause non-selected pixel to be activated.
If such a phenomenon is observed, check the voltage level of the power supply.
- 8-2. The DC/DC converter generates approximately 60Vdc, avoid touching it with bare hands, or to other circuits.
- 8-3. Avoid using the module where excessive noise interface is expected.
Noise affects the interface signal and causes improper operation.
Keep the length of the interface cable less than 30cm.
(When the longer cable is required, please confirm there is no noise affection.)
- 8-4. When power is turned off, the capacitor will not discharge immediately.
Avoid touching IC and others.
The shorting of the mounted components within 30 sec., after power off, may cause damage.
- 8-5. When fixed pattern is displayed for a long time, you may see uneven luminance.
It is recommended to change the display patterns sometimes in order to keep best display quality.
- 8-6. DC/DC converter is equipped on the module, the surge current may be approximately 5 times the specified supply current at the power on.