

APPLICATION NOTE

VACUUM FLUORESCENT DISPLAY MODULE

AN-E-2221A



To: Sandi

DOT MATRIX VFD MODULE M204LD01AA

INSTRUCTION MANUAL

GENERAL DESCRIPTION

Futaba Vacuum Fluorescent Display Module M204LD01AA, with Futaba VFD 204-LD-01GN display, produces 20 digits on 4 rows.

Each character is displayed in 5×7 dot matrix.

Consisting of a VFD, microcomputer, driver IC, the module can be connected directly to the system bus, thus simplifying interfacing.

The bright and aesthetic pleasing VFD makes the module desirable for application in office equipments, such as electronic typewriters, computer terminals, measuring equipment, etc.

FUTABA

1. FEATURES

- 1-1. Microcomputer is equipped on the module and it realizes intelligent terminal.
The module can be connected to the system bus directly.
- 1-2. Two hundred and twenty four character fonts consisting of alphabets, numeral, and other symbols can be displayed.
- 1-3. Since a DC/DC converter is included, only 5Vdc power source is required to operate the module.
- 1-4. High quality and reliability, also long life can be achieved with FUTABA VFD.

2. GENERAL SPECIFICATIONS

2-1. DIMENSIONS, WEIGHT (Refer APPENDIX-1)

TABLE-1

Item	Specification	Unit
Outer Dimensions	(W) 290±1 (H) 100±1 (T) 40 MAX. (Without connector)	mm
Weight	APPROX. 840	g

2-2. SPECIFICATIONS OF THE DISPLAY PANEL

TABLE-2

Item	Specification	Unit
Display area	202×54.2	mm
Number of digits	20digits(5×7)×4rows	-
Digits size (H×W)	11.3×7.25	mm
Digits pitch (H×W)	10.25×14.3	mm
Color of illumination	Green (505nm)	-

2-3. ENVIRONMENT CONDITIONS

TABLE-3

Item	Symbol	Min.	Max.	Unit
Operating temperature	Topr	-10	+60	°C
Storage temperature	Tstg	-20	+85	°C
Operating humidity	Hopr	20	85	%
Storage humidity	Hstg	20	95	%
Vibration (10 to 55 Hz)	-	-	4	G
Shock	-	-	40	G

Note) Avoid operations and or storage in moist environmental conditions.

2.4. ABSOLUTE MAXIMUM RATINGS

TABLE-4

Item	Symbol	Min.	Max.	Unit
Supply voltage	V _{CC}	-0.3	6.5	V _{dc}
Input signal voltage	V _{IS}	-0.3	5.5	V

2.5. RECOMMENDED OPERATING CONDITIONS

TABLE-5

Item	Symbol	Condition	Min.	Typ.	Max.	Unit
Supply voltage	V _{CC}	-	4.5	5.0	5.5	V _{dc}
H-level input voltage	V _{IH}	V _{CC} =5V	2.6	-	-	V
L-level input voltage	V _{IL}	V _{CC} =5V	-	-	0.5	V

2.6. ELECTRICAL CHARACTERISTICS

TABLE-6

Item	Symbol	Condition	Min.	Typ.	Max.	Unit
Supply current	I _{CC}	V _{CC} =5V	-	2.2	2.7	A
Power consumption	-		-	11	13.5	W
Luminance	L	All on	300 (88)	600 (175)	-	cd/m ² (fL)
H-level input current	I _{IH}	V _{CC} =5V	-	-	20	μA
L-level input current	I _{IL}	V _{CC} =5V	-0.6	-	-	mA
H-level output voltage	V _{OH}	V _{CC} =5V I _{OH} =-2mA	3.5	-	-	V
L-level output voltage	V _{OL}	V _{CC} =5V I _{OL} =6mA	-	-	0.5	V

OUTER DIMENSIONS

APPENDIX-1

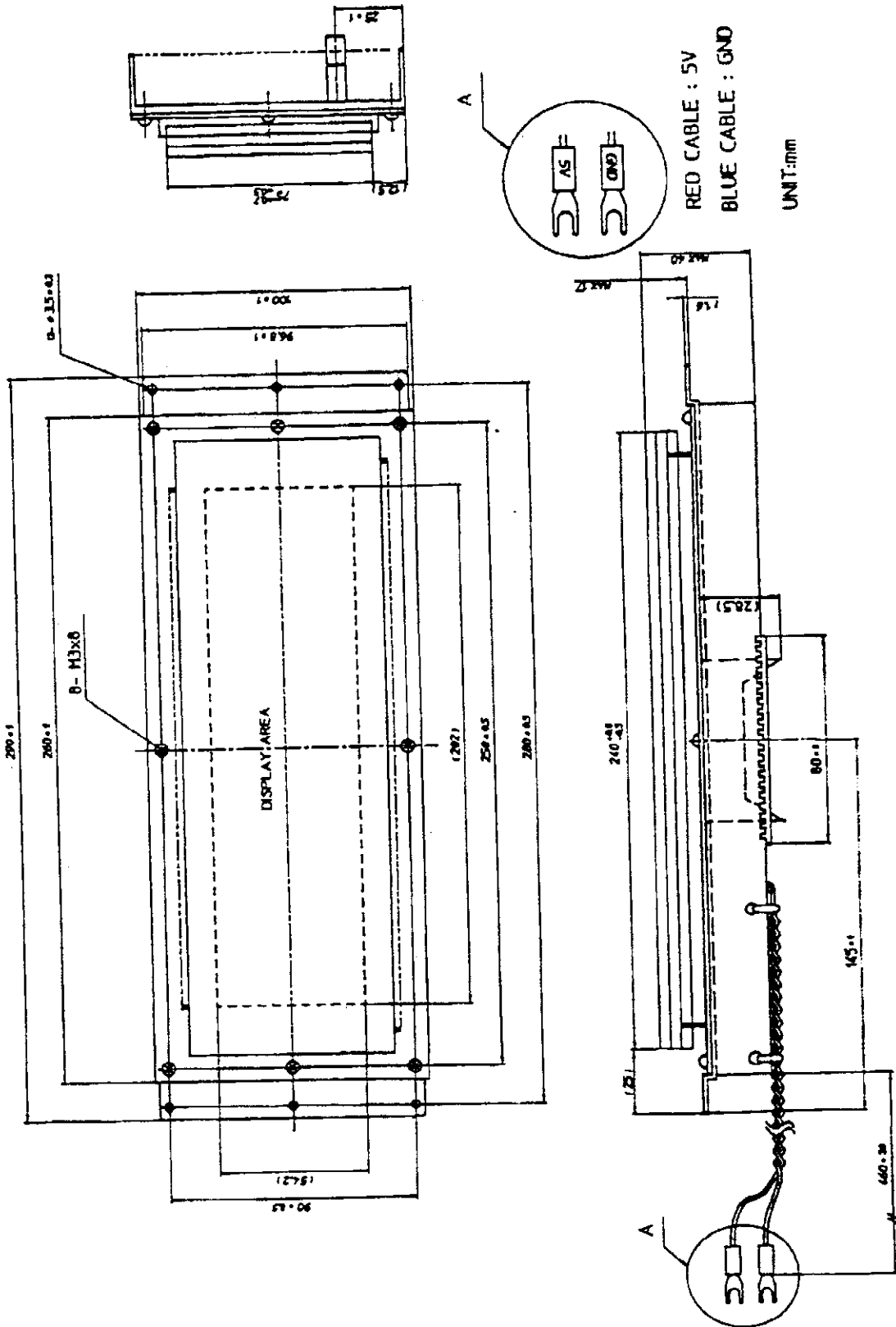

CIRCUIT BLOCK DIAGRAM

APPENDIX-2

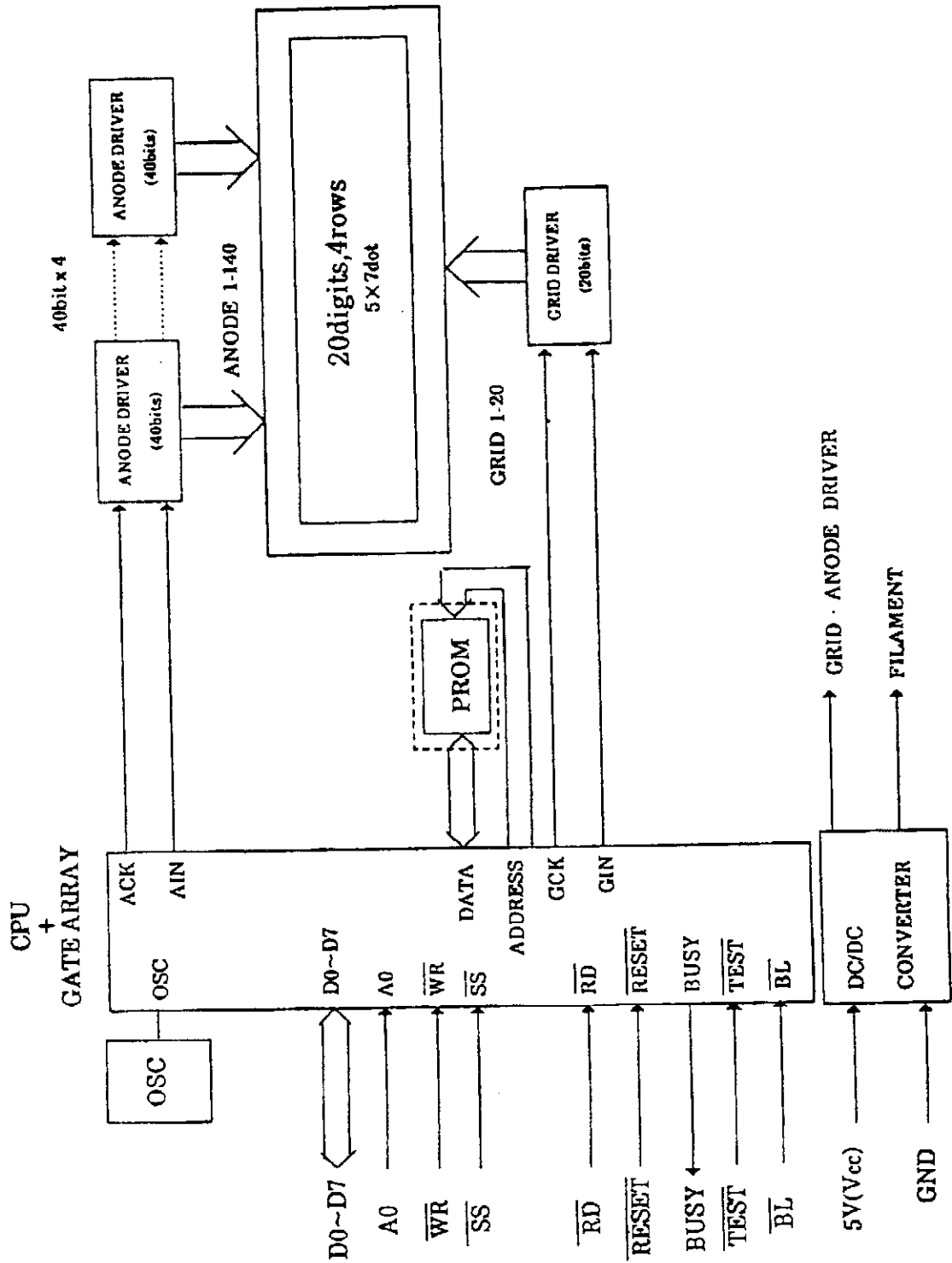

CHARACTER FONT CODE

APPENDIX-3

	0020	0021	0010	0011	0100	0101	0110	0111	1000	1001	1010	1011	1100	1101	1110	1111
xxxx0000			SPACE	0	a	P	'	F	A	z		—	9	三	↑	△
xxxx0001		DC1	!	1	A	Q	3	9	ä	Ä	■	フ	7	4	↓	△
xxxx0010		DC2	"	2	B	R	b	r	ö	Ö	■	「	イ	ウ	×	±
xxxx0011			#	3	C	S	c	s	ä	Ä	■	」	ウ	テ	≠	≠
xxxx0100			\$	4	D	T	d	t	ü	Ü	■	「	エ	ト	†	—
xxxx0101			%	5	E	U	e	u	ö	Ö	■	「	オ	大	1	2
xxxx0110			&	6	F	V	f	v	B	R	■	「	カ	二	三	3
xxxx0111			'	7	G	W	g	w	ä	Ä	■	「	キ	ヲ	ヲ	キ
xxxx1000	BS		(8	H	X	h	x	ä	Ä	■	「	ク	キ	リ	×
xxxx1001	HT)	9	I	Y	i	y	ä	Ä	■	「	ケ	ル	÷	5
xxxx1010	LF		*	#	J	Z	j	z	ä	Ä	■	「	コ	ン	レ	△
xxxx1011	VT	ESC	+	#	K	C	k	c	ä	Ä	■	「	ク	レ	ロ	フ
xxxx1100	CLR		,	<	L	¥	l	¥	ä	Ä	■	「	ク	レ	ル	≠
xxxx1101	CR		—	=	M	I	m	i	ä	Ä	■	「	ク	レ	ル	≠
xxxx1110				.	>	N	^	n	ä	Ä	■	「	ク	レ	ル	≠
xxxx1111			≡	/	?	0	_	o	ä	Ä	■	「	ク	レ	ル	≠